

CENTRAL MACHINERY®

16 SPEED FLOOR DRILL PRESS

Model 43378

SET UP AND OPERATING INSTRUCTIONS



Diagrams within this manual may not be drawn proportionally.

Due to continuing improvements, actual product may differ slightly from the product described herein.

Distributed exclusively by Harbor Freight Tools®.

3491 Mission Oaks Blvd., Camarillo, CA 93011

Visit our website at: <http://www.harborfreight.com>



**Read this material before using this product.
Failure to do so can result in serious injury.
SAVE THIS MANUAL.**

Copyright© 2000 by Harbor Freight Tools®. All rights reserved. No portion of this manual or any artwork contained herein may be reproduced in any shape or form without the express written consent of Harbor Freight Tools.

For technical questions or replacement parts, please call 1-800-444-3353.

Cover revised 071

Specifications

Motor	120 VAC, 60 Hz, 3/4 HP, 1750 RPM; 5.8 amps (with load)
16 Spindle Speeds	220, 300, 430, 480, 590, 650, 720, 850, 950, 1600, 1900, 2000, 2500, 2900, and 3600 RPM
Spindle	Stroke: 3-1/8 inches; Taper: MT2
Column	2-7/8 (diameter) inches
Base Dimensions	10-1/8 x 17-1/2 inches; Slots: 5/8"
Throat Depth	6-5/8 inches (of 13 inch swing)
Chuck Capacity	7/64 to 5/8 inches; Taper: JT3
Table Slot	5/8 inches
Table Rotation	360°; Tilt: 45° (left and right)
Table Size	11-5/8 (diameter) inches



Save This Manual

You will need the manual for the safety warnings and precautions, assembly instructions, operating and maintenance procedures, parts list and diagram. Keep your invoice with this manual. Write the invoice number on the inside of the front cover. Keep the manual and invoice in a safe and dry place for future reference.

Safety Warnings and Precautions

WARNING: When using tool, basic safety precautions should always be followed to reduce the risk of personal injury and damage to equipment.

Read all instructions before using this tool!

1. **Keep work area clean.** Cluttered areas invite injuries.
2. **Observe work area conditions.** Do not use machines or power tools in damp or wet locations. Don't expose to rain. Keep work area well lighted. Do not use electrically powered tools in the presence of flammable gases or liquids.
3. **Keep children away.** Children must never be allowed in the work area. Do not let them handle machines, tools, or extension cords.
4. **Store idle equipment.** When not in use, tools must be stored in a dry location to inhibit rust. Always lock up tools and keep out of reach of children.
5. **Do not force tool.** It will do the job better and more safely at the rate for which it was intended. Do not use inappropriate attachments in an attempt to exceed the tool capacity.
6. **Use the right tool for the job.** Do not attempt to force a small tool or attachment to

REV 00j

do the work of a larger industrial tool. There are certain applications for which this tool was designed. Do not modify this tool and do not use this tool for a purpose for which it was not intended.

7. **Dress properly.** Do not wear loose clothing or jewelry as they can be caught in moving parts. Protective, electrically non-conductive clothes and non-skid footwear are recommended when working. Wear restrictive hair covering to contain long hair.
8. **Use eye and ear protection.** Always wear ANSI approved impact safety goggles. Wear a full face shield if you are producing metal filings or wood chips. Wear an ANSI approved dust mask or respirator when working around metal, wood, and chemical dusts and mists.
9. **Do not overreach.** Keep proper footing and balance at all times. Do not reach over or across running machines.
10. **Maintain tools with care.** Keep tools sharp and clean for better and safer performance. Follow instructions for lubricating and changing accessories. Inspect tool cords periodically and, if damaged, have them repaired by an authorized technician. The handles must be kept clean, dry, and free from oil and grease at all times.
11. **Disconnect power.** Unplug when not in use.
12. **Remove adjusting keys and wrenches.** Check that keys and adjusting wrenches are removed from the tool or machine work surface before plugging it in.
13. **Avoid unintentional starting.** Be sure the switch is in the Off position when not in use and before plugging in.
14. **Stay alert.** Watch what you are doing, use common sense. Do not operate any tool when you are tired.
15. **Take caution as some woods contain preservatives such as copper chromium arsenate (CCA) which can be toxic.** When cutting these materials extra care should be taken to avoid inhalation and minimize skin contact.
16. **Check for damaged parts.** Before using any tool, any part that appears damaged should be carefully checked to determine that it will operate properly and perform its intended function. Check for alignment and binding of moving parts; any broken parts or mounting fixtures; and any other condition that may affect proper operation. Any part that is damaged should be properly repaired or replaced by a qualified technician. Do not use the tool if any switch does not turn On and Off properly.
17. **Guard against electric shock.** Prevent body contact with grounded surfaces such as pipes, radiators, ranges, and refrigerator enclosures.
18. **Replacement parts and accessories.** When servicing, use only identical replacement parts. Use of any other parts will void the warranty. Only use accessories intended for use with this tool. Approved accessories are available from Harbor Freight Tools.

19. **Do not operate tool if under the influence of alcohol or drugs.** Read warning labels on prescriptions to determine if your judgment or reflexes are impaired while taking drugs. If there is any doubt, do not operate the tool.
20. **Use proper size and type extension cord.** If an extension cord is required, it must be of the proper size and type to supply the correct current to the tool without heating up. Otherwise, the extension cord could melt and catch fire, or cause electrical damage to the tool. This tool requires use of an extension cord of **0 to 12 amps** capability (up to 50 feet), with wire size rated at **16 AWG**. Longer extension cords require larger size wire (smaller AWG number). If you are using the tool outdoors, use an extension cord rated for outdoor use. (signified by “WA” on the jacket).
21. **Secure Workpiece.** Use clamps or a vise to hold workpiece, if possible. Never hold workpiece with your hands.
22. **Never leave Drill Press running unattended.** Turn the power OFF.
23. **Maintenance.** For your safety, service and maintenance should be performed regularly by a qualified technician.
24. **People with pacemakers should consult their physician(s) before use.** Electromagnetic fields in close proximity to heart pacemaker could cause pacemaker interference or pacemaker failure.
25. **WARNING: This product contains or, when used, produces a chemical known to the State of California to cause cancer and birth defects or other reproductive harm. (California Health & Safety Code § 25249.5, et seq.)**

Note: Performance of this tool may vary depending on variations in local line voltage. Extension cord usage may also affect tool performance.

Warning: The warnings, cautions, and instructions discussed in this instruction manual cannot cover all possible conditions and situations that may occur. It must be understood by the operator that common sense and caution are factors which cannot be built into this product, but must be supplied by the operator.

VIBRATION HAZARD

This tool vibrates during use. Repeated or long-term exposure to vibration may cause temporary or permanent physical injury, particularly to the hands, arms and shoulders. To reduce the risk of vibration-related injury:

1. Anyone using vibrating tools regularly or for an extended period should first be examined by a doctor and then have regular medical check-ups to ensure medical problems are not being caused or worsened from use. Pregnant women or people who have impaired blood circulation to the hand, past hand injuries, nervous system disorders, diabetes, or Raynaud's Disease should not use this tool. If you feel any medical or physical symptoms related to vibration (such as tingling, numbness, and white or blue fingers), seek medical advice as soon as possible.
2. Do not smoke during use. Nicotine reduces the blood supply to the hands and fingers, increasing the risk of vibration-related injury.
3. Wear suitable gloves to reduce the vibration effects on the user.
4. Use tools with the lowest vibration when there is a choice between different processes.
5. Include vibration-free periods each day of work.
6. Grip tool as lightly as possible (while still keeping safe control of it). Let the tool do the work.
7. To reduce vibration, maintain the tool as explained in this manual. If any abnormal vibration occurs, stop use immediately.

Drill Press Safety Warnings and Precautions

1. Secure the Drill Press Base (B6) to the floor using Bolts (not supplied). The floor must be level, smooth and capable of supporting the weight of the drill press and workpieces.
2. Locate the Drill Press in an area where you walk around it unhampered.
3. Avoid kickback and grabbing by clamping the workpiece to the table, or use a vise that is secured to the table. If the workpiece begins to spin, do not attempt to stop it with your hands. Turn the motor OFF, and wait until it stops spinning before attempting to remove it.
4. Avoid being caught and pulled into the spinning chuck. Do not wear gloves, long sleeve shirts, ties, or jewelry. Long hair must be bundled behind the head.

5. Never place hands and arms near the workpiece to avoid the possibility of the work piece coming loose and striking you.
6. Before drilling, turn on the motor and check for bit wobble or machine vibration. If this is found, correct the problem before drilling.
7. Set the proper spindle speed for the specific drilling operation.
8. When finished with the Drill Press, always press the Switch to the OFF position, and remove the Lock Key.
9. Do not mount (or adjust) the workpiece on the Drill Press Table while the motor is running.
10. When drilling or cutting large holes, use the slower speeds and securely fasten the workpiece to the table using a mounted vise.
11. Do not use drill bits that extend more than six inches from the Chuck.
12. Do not use circle cutters, rotary planers, wire wheels, router bits, or shaper cutters on this Drill Press.

Unpacking

When unpacking, check to make sure the following parts are included.

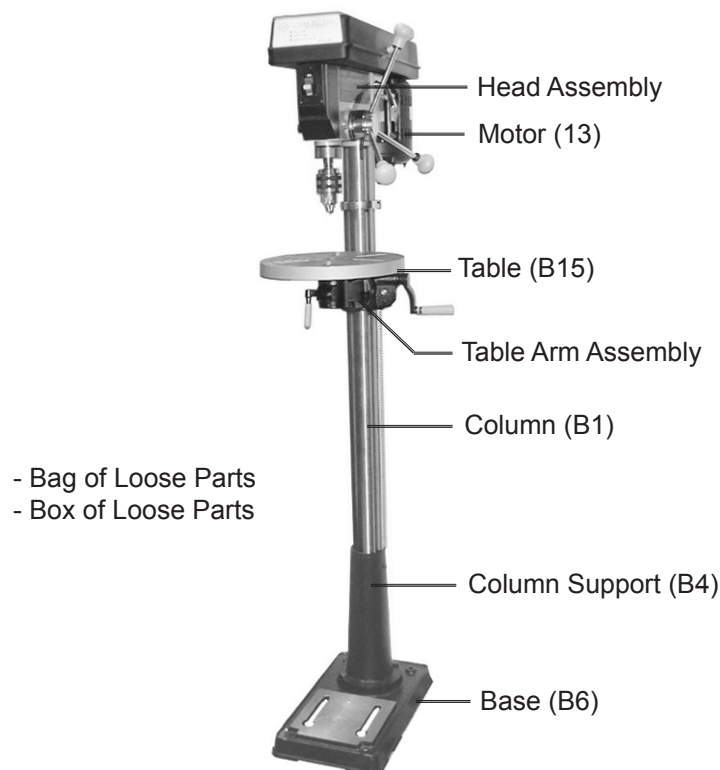

If any parts are missing or broken, please call Harbor Freight Tools at the number on the cover of this manual as soon as possible.

Assembly

Assembly hardware is located in separate bags. Each bag contains the necessary parts for each assembly step. Remove all packing and protective material from the Drill Press components.

1. Position the **Base** (B6) on a level floor.
It is recommended to bolt the Base to the floor using appropriate hardware (not supplied).

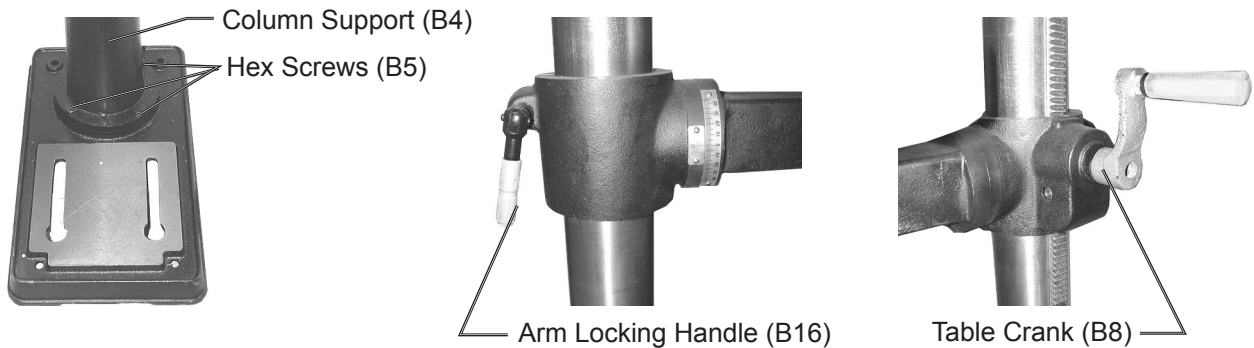

2. Place the **Column Support** (B4) on the Base, aligning the mounting holes.
3. Insert four large Hex Screws (B5) into the mounting holes and tighten with a wrench.
4. Install the **Arm Locking Handle** (B16) on the left side of the Table Support (B7). Hand Tighten.
5. Mount the **Table Crank** (B8) onto the right side of the Table Support.
Tighten with the Allen wrench. The set screw must be tightened against the flat portion of the screw shaft.
6. Verify that the Column **Collar** (B19) is square to the Column and that the Set Screw (B11) is secure (but not overtightened).

The Collar should be positioned so that its rack will slide freely in the collar when the Table (B15) is rotated around the Column.



7. Loosen the Table Clamp (B13) and insert the **Table** (B15) into the Table **Arm** (B14).
It may be necessary to pry open the Table Arm opening with a large screwdriver since it is meant to be a tight fit. With the Table in place, retighten the Table Clamp.

CAUTION: Avoid injuries. The next step involves lifting the Head Assembly onto the Column Tube. The Head Assembly weighs about 55 lb. Have someone help you lift this assembly into place.

Rev 07i

8. Using two people, lift the **Head Assembly** up and onto the Column (B1).
It should slide down on the Column Tube as far as it will go. Align it so that it faces straight forward, inline with the Base.
9. Screw in two Set Screws (21), into each side of the Head (1) and tighten with the Allen wrench.

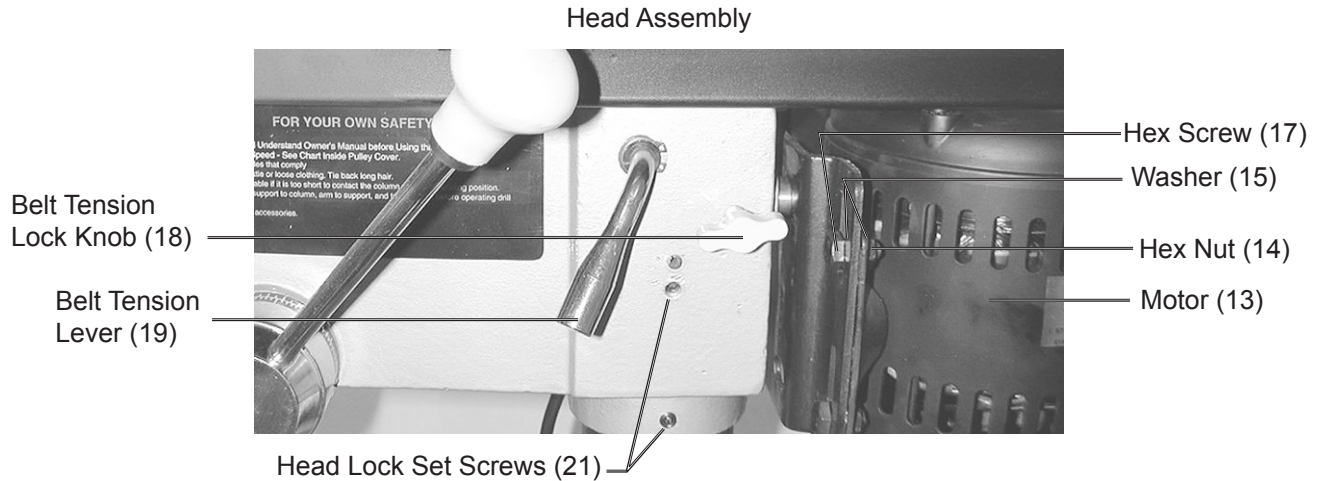

10. Mount the **Motor** (13) onto the Head Assembly (see photo above).
 - Place a Washer (15) on each of four Hex Screws (17)
 - Insert Hex Screws into the Motor Mount (8) (from left to right as shown above).
 - Position the Motor base slots over the Hex Screws.
 - Place a Washer (15) and Hex Nut (14) on each Hex Screw (17). Hand tighten.
 - Position the Motor shaft at the center of the Pulley Cover (A23).
11. Install the **Motor Pulley** (11).
 - Slide the Motor Pulley onto the Motor shaft.
 - Line up the flat notch on the shaft with flat notch on the pulley.
 - The pulley should not touch the lower Pulley Cover (A23).
 - Tighten the Motor Pulley onto the shaft using the Allen wrench and Set Screw (12).



12. Adjust the height of the Motor Pulley.
 - Lay a straight edge across the two pulleys.

- Push the Motor up until the top of the pulleys align. Hold Motor in place.
- Using a wrench, tighten four Hex Nuts (14) supporting the Motor.
- Turn the Belt Tension Lever (19) counterclockwise to release belt tension.

13. Install **V-belts** (A1). Refer to the photos on page 7.

- Turn the Belt Tension Lever (19) and move the pulleys closer together.
- Place the Idler Pulley (A19) on the Idler Pivot (A20), and into the Pulley Cover center hole (See the Pulley Assembly Drawing at the end of this manual).
- Place the V-belt between Spindle Pulley (A3) and the Idler Pulley (A19).
- Refer to the chart inside the Pulley Guard lid to select speed and belt locations.
- Place V-belt between the Motor Pulley (11) and the Idler Pulley (A19).
- Turn the Belt Tension Lever (19) to tighten the belts (moderately), and hold in place.
- Turn the Belt Tension Lock Knobs (18) clockwise to lock the belt tension.

Note: To test the proper belt tension, push in on the center of each belt at its center. It should move only 1/2 inch (in or out).

Caution: overtightening the belts can cause the motor to bind, and not start. It can also damage Motor bearings.

14. Attach Knob (A21) to the (top) Pulley Cover using Screw (A22).

Warning: Do not plug line cord into the electrical outlet at this time.

15. Locate the three Feed Handles (24) and screw them firmly into the Spindle Feed Shaft (25).

16. Install the **Chuck** (A15).

- Thoroughly clean the tapered hole in the Chuck and the Arbor (A14) of all dirt, grease, oil, and protective coatings.
- Slide the Chuck onto the Arbor.
- Loosen the Arm Locking Handle (B16) and turn the Table Crank (B8) to raise the Table so that it is about two inches from the Chuck.
- Turn the Chuck sleeve clockwise and open the jaws completely.
- Turn the Feed Handle counterclockwise and force the Chuck against the Table until it is secure.

17. Verify that the Table is square (90 degrees) to the Head Assembly and drill bit.

- Secure a three inch drill bit in the Chuck.
- Raise the Table to within four inches of the Chuck.
- Place the long side of a combination square on the Table.
- Align the short side of the square to the drill bit.
- If the Table is not square to the bit, loosen Set Screw (B11) with the Allen wrench and the Lock Screw (B12) with a Hex Wrench.
- Rotate the Table until it is square to the bit.
- Retighten the Lock Screw, then the Set Screw.

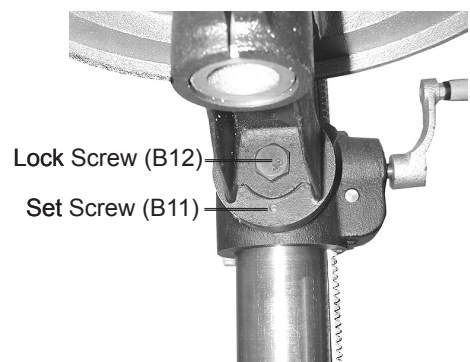

Operation

Warning: Avoid personal injuries. Before operating this machine, review all Safety Warnings and Precautions listed on pages 2 through 5.

1. Loosen the Arm Locking Handle (B16) and turn the Table Crank (B8) to adjust the Table height to accommodate the workpiece being drilled.
2. Open the Chuck and insert the drill bit in the center. Tighten with the Chuck Key (A16).
3. Secure the workpiece (and backup material) to the Table using a vise and/or clamp.
The workpiece sits on the backup material. To keep it from spinning, have it touching the left side of the Column.
4. Adjust the height and left/right position of the Table. Tighten the Arm Locking Handle (B16).
5. Bring the drill bit down with the Feed Handles to where the hole is to be drilled.
Make minor workpiece alignment adjustments.
6. Plug the Motor Cable (16) plug into an electrical outlet.
7. Insert the Switch Key into the Switch (31).

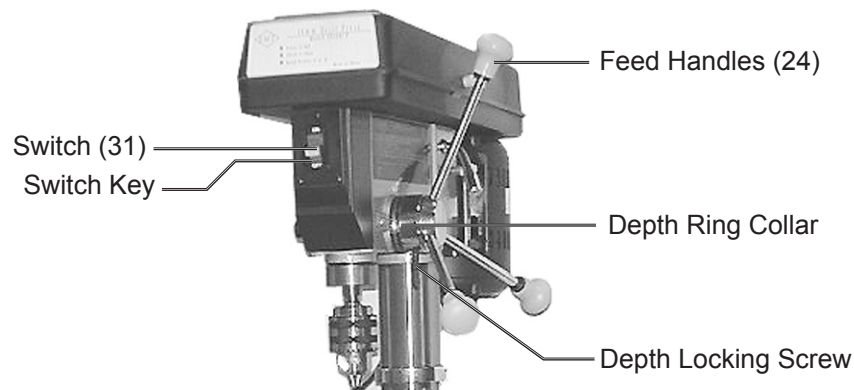

Warning: Wear an ANSI approved, full face shield while drilling any type of material.

8. Push the Switch up to turn the Motor ON.
9. Pull down on the Feed Handle and slowly drill the hole into the workpiece.

Warning: If the drill bit grabs and spins the workpiece, do not attempt to stop the spinning with your hands. Step back, and push the Switch down to the OFF position. Wait for the spindle to stop turning before dislodging the workpiece.

10. When the drilling is complete, press the Switch to the OFF position and remove the Switch Key.

Keep the Switch Key in a safe place.

Setting the Depth Scale to Drill to a Specified Depth

During this procedure, refer to the photo on page 9.

1. Secure the workpiece to the Table.

Rev 07i

2. Mark the desired hole depth on the side of the workpiece.
3. Loosen the Depth Locking Screw Lock.
4. Turn the Feed Handle counterclockwise to bring the tip of the drill bit down, next to the hole depth mark.
5. Turn the Depth Stop Collar counterclockwise until it stops moving.
6. Tighten the Depth Locking Screw.
7. Turn the Drill Press ON and turn the Feed Handle counterclockwise until it drills the hole and stops at the set depth.
8. Turn the Drill Press OFF.

Using the Depth Scale to Measure Depth While Drilling

1. Secure the workpiece to the Table.
2. Loosen the Depth Locking Screw.
3. Adjust the Table height so that the tip of the drill bit is just above the workpiece.
4. Turn the Depth Stop Collar clockwise to "0."
5. Tighten the Depth Locking Screw.
6. Turn the Drill Press ON and turn the Feed Handle counterclockwise to drill the hole. While drilling, watch the pointer and scale on the Depth Stop Collar. Stop turning the Feed Handle when the pointer and scale indicate the desired depth.
7. Turn the Drill Press OFF.

Locking the Chuck at a Specific Depth

1. Loosen the Depth Locking Screw.
2. Turn the Feed Handle counterclockwise to bring the Chuck to the desired depth.
3. Turn the Depth Stop Collar clockwise until it stops.
4. Tighten the Depth Locking Screw.
The Chuck will be held at this position when the Feed Handle is released.

Tilting the Table

1. Loosen Set Screw (B11) under the Arm assembly with the Allen wrench.
2. Loosen the Lock Screw (B12) with the Hex Wrench.
3. Rotate the Table to the desired angle.
The scale can be used to approximate the angle.
4. Retighten the Lock Screw, then the Set Screw.

Maintenance

Warning: Before performing any maintenance to this machine, remove the line cord from the electrical outlet.

Removing the Chuck and Arbor

During this procedure, refer to the Pulley and Spindle Assembly Drawing.

1. Adjust the Depth Stop Collar to hold the Chuck at a depth of three inches.
2. Align the key holes in the Spindle Shaft (A13) and the Quill (A11) by turning the Chuck by hand.
3. Insert the Wedge Drift Key (A17) into the key holes.
4. Lightly tap the Wedge Drift Key with a rubber mallet until the Arbor (A14) falls out of the Spindle.

Place a bundled cloth or basket below the Chuck to catch it when it falls.

Installing the Chuck and Arbor

1. Using a clean cloth, wipe the tapered surfaces on the Arbor and Spindle.
2. Slide the Arbor and Chuck assembly up and into the Spindle.

At the same time, turn the assembly until the rectangular end of the Arbor slips into the notch on the Spindle.

Warning: In the previous step, if the Arbor is not properly set in the Spindle notch, it may fly out during operation.

3. Loosen the Arm Locking Handle (B16) and raise the Table about three inches below the Chuck.
4. Turn the Chuck sleeve clockwise to open the jaws completely.
5. Turn the Feed Handle counterclockwise and force the Chuck against the Table until the Arbor is secure.

Adjusting the Feed Handle Return Quill Spring

Caution: Wear a full face shield during this procedure.

1. Loosen the Depth Locking Screw.
2. Move the Chuck to its uppermost position.
3. Turn the Depth Stop Collar clockwise until it stops.
4. Tighten the Depth Locking Screw.

This will prevent the Chuck and Arbor assembly from dropping during Quill Spring adjustment.

5. Insert a screwdriver in the lower-front notch of the Quill Spring Cap (39).

Hold it in place and, using a wrench, remove the (outer) Hex Nut (38) only.

Rev 07i

6. With the screwdriver still in place, loosen the (inner) Hex Nut (38) until the Quill Spring Cap notch disengages from the Spring Seat (42) -- about 1/8 inch.

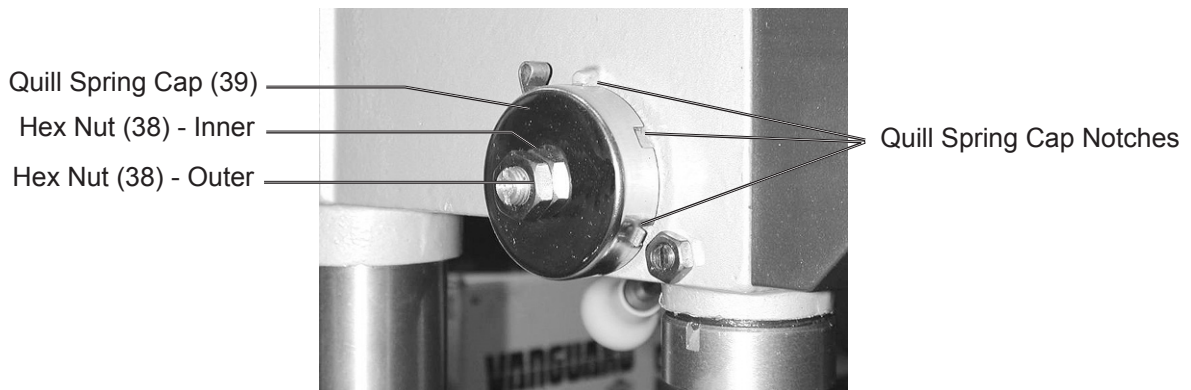

7. Turn the screwdriver counterclockwise and engage the next Spring Cap notch. Leave the screwdriver in place.
8. Tighten the (inner) Hex Nut just enough to engage the notch. If this Hex Nut is too tight, it will restrict (up and down) Chuck-Arbor movement.
9. Turn the Feed Handle and check the spring tension, making sure the up movement is smooth and complete. From one inch down, the Chuck should return to its uppermost position. If more tension is required, repeat steps 5 through 9.
10. Replace the (outer) Hex Nut and tighten on top of the (inner) Hex Nut. Do not overtighten.
11. If the (up/down) movement is restricted, slightly loosen the (inner) Hex Nut, and retighten the (outer) Hex Nut.

General Maintenance

1. Using compressed air, blow clean the Table, Base, and Motor cooling vents of dirt and materials.
2. Apply paste wax to the Table and Column to enable movement and to help keep surfaces clean.
3. All bearings are factory lubricated and need no further attention.
4. Periodically, lubricate the Tube Column teeth, Table gears, and Spindle upper teeth.
5. Monthly, check the tightness of all mounting screws and bolts in the Base, Column, and Head assemblies.
6. Check belts for wear and replace if frayed or damaged in any way.
7. Lubricate Spindle assembly with a light oil, weekly.
8. Periodically, grease the rack.
9. Store in a clean and dry location.

Rev 07i

Troubleshooting

SYMPTOM	POSSIBLE CAUSE	SOLUTION
Drill bit burns or smokes	<ul style="list-style-type: none"> - Incorrect spindle speed - Dull drill bit - Drilling too slowly - Lacking lubrication 	<ul style="list-style-type: none"> - Change spindle speed - Replace with new bit - Drill faster - Lubricate cutting area
Makes unusual noise	<ul style="list-style-type: none"> - Belt tension set wrong - Spindle dry - Loose spindle pulley - Loose motor pulley 	<ul style="list-style-type: none"> - Adjust belt tension - Lubricate spindle - Check pulley nut - Tighten Set screws
Drill bit wobbles	<ul style="list-style-type: none"> - Bent bit - Worn Spindle Bearings - Drill bit not in Chuck correctly - Chuck not properly installed 	<ul style="list-style-type: none"> - Replace drill bit - Replace spindle bearings - Reinstall drill bit - Reinstall Chuck and Arbor assembly
Feed Handle returns slowly, or too fast	<ul style="list-style-type: none"> - Adjust Quill Spring 	<ul style="list-style-type: none"> - Adjust Quill Spring. See page 11.
Drill bit binds	<ul style="list-style-type: none"> - Workpiece pinching drill bit - Dull drill bit - Feed pressure too hard - Belts loose 	<ul style="list-style-type: none"> - Reposition workpiece, lubricate drill - Replace drill bit - Pull Feed Handle slowly. - Adjust motor and spindle belt tension

PLEASE READ THE FOLLOWING CAREFULLY

THE MANUFACTURER AND/OR DISTRIBUTOR HAS PROVIDED THE PARTS DIAGRAM IN THIS MANUAL AS A REFERENCE TOOL ONLY. NEITHER THE MANUFACTURER NOR DISTRIBUTOR MAKES ANY REPRESENTATION OR WARRANTY OF ANY KIND TO THE BUYER THAT HE OR SHE IS QUALIFIED TO MAKE ANY REPAIRS TO THE PRODUCT OR THAT HE OR SHE IS QUALIFIED TO REPLACE ANY PARTS OF THE PRODUCT. IN FACT, THE MANUFACTURER AND/OR DISTRIBUTOR EXPRESSLY STATES THAT ALL REPAIRS AND PARTS REPLACEMENTS SHOULD BE UNDERTAKEN BY CERTIFIED AND LICENSED TECHNICIANS AND NOT BY THE BUYER. THE BUYER ASSUMES ALL RISK AND LIABILITY ARISING OUT OF HIS OR HER REPAIRS TO THE ORIGINAL PRODUCT OR REPLACEMENT PARTS THERETO, OR ARISING OUT OF HIS OR HER INSTALLATION OF REPLACEMENT PARTS THERETO.

Head Assembly Parts List

Item #	Description
1	Head w/pointer and trim
2	Cable Clamp
3	Pan Head Screw, M5x12
4	Hex Screw, M8x16
5	Adjusting Lever
6	Motor Support Bracket
7	Motor Support Bracket
8	Motor Mount
9	Lock Washer, o12
10	Hex Nut, M12x1.75
11	Motor Pulley
12	Set Screw, Socket, M6x10
13	Motor
14	Hex Nut, M8
15	Washer, o8
16	Motor Cable
17	Hex Screw, M8x20
18	Belt Tension Lock Knob
19	Belt Tension Lever
20	Roll Pin
21	Set Screw, Head Lock, M8x25
22	Depth Lock Screw
23	Knob

Item #	Description
24	Feed Handle
25	Spindle Feed Shaft
26	Collar Depth Stop, w/Scale
27	Stop Pin
28	Connector Wire
29	Lock Washer, Ext., 5mm
30	Pan Head Screw, M5x12
31	Switch
33	Switch Plate Cover
34	Pan Head Screw, ST4.2x9.5
35	Switch Box, M5
36	Switch Box
37	Set Screw, Special, M8
38	Hex Nut, M12
39	Quill Spring Cap
40	Quill Spring
41	Spring Retainer
42	Spring Seat
43	Power Cable
44	Cable Tie
45	Allen Wrench, 4mm
46	Allen Wrench, 3mm

NOTE: Some parts are listed in these Part Lists are shown for illustration purposes only and are not available individually as replacement parts.

Head Assembly Drawing

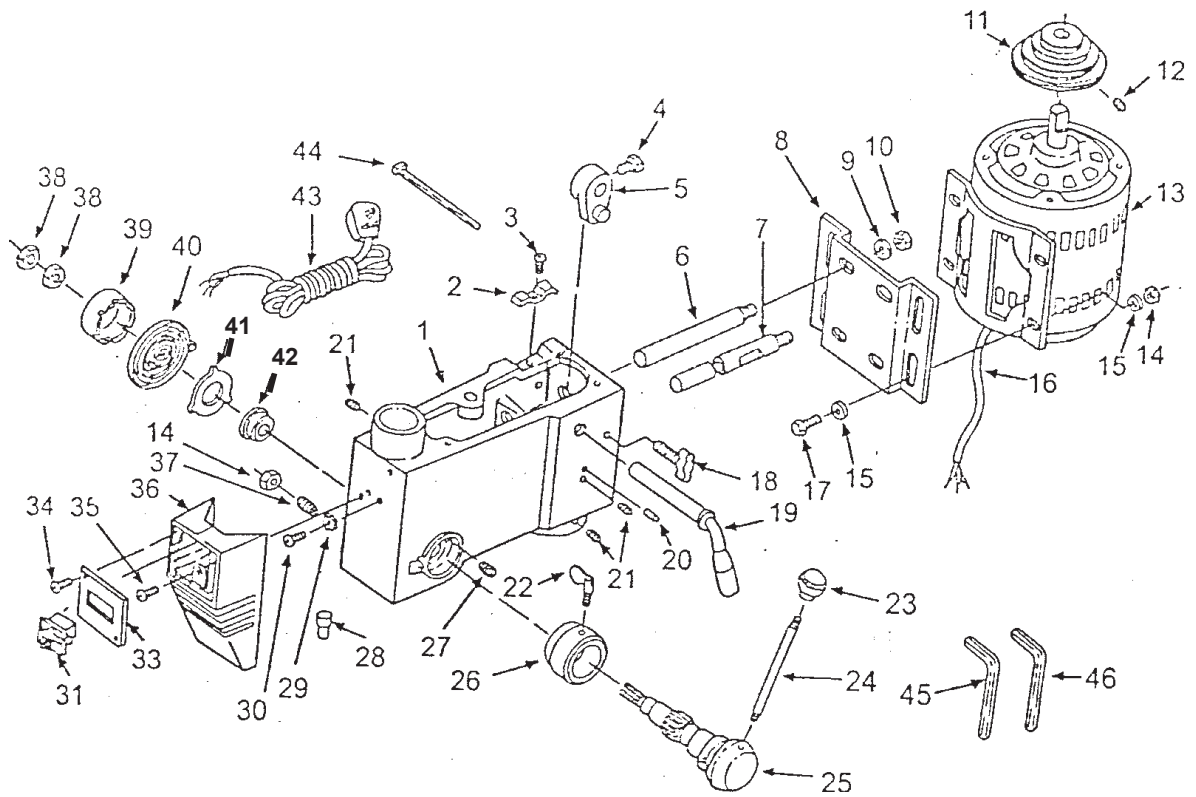

Pulley and Spindle Assembly Parts List

Item #	Description
A1	V Belt, M24
A2	Pulley Nut
A3	Spindle Pulley
A4	Pulley Insert
A5	Ball Bearing
A6	Spacer
A7	Retaining Ring, 17 mm
A8	Retaining Ring, 11 mm
A9	Ball Bearing
A10	Quill Gasket
A11	Quill
A12	Ball Bearing
A13	Spindle Shaft
A14	Arbor
A15	Chuck
A16	Chuck Key
A17	Wedge Drift Key
A18	Ball Bearing
A19	Idler Pulley
A20	Idler Pivot
A21	Knob
A22	Pan Head Screw, M5x8
A23	Pulley Cover
A24	Washer, HD Screw, M16x12
A25	Foam Washer

Pulley and Spindle Assembly Drawing

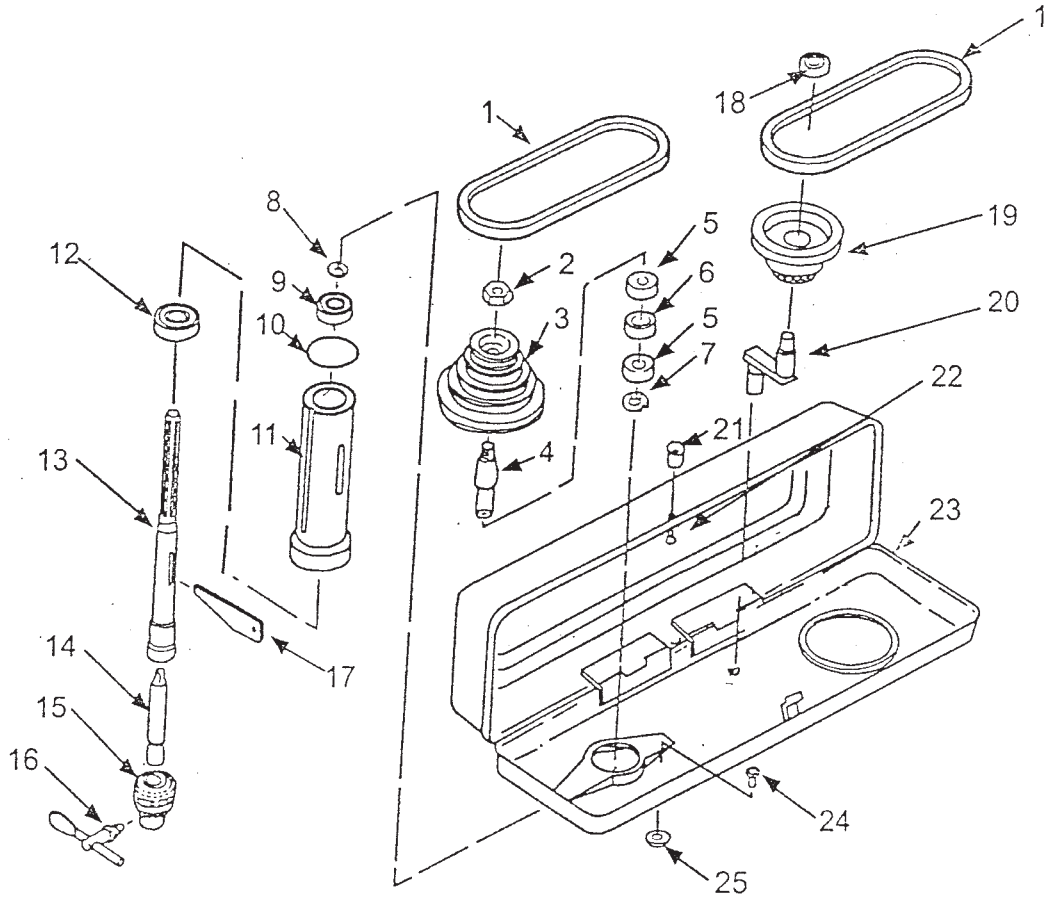

When ordering a part from this drawing, add an "A" prefix to the part number.

Base and Table Assembly Parts List

Item #	Description
B1	Column
B2	Rack
B3	Set Screw, Hex. Socket, M10x12
B4	Column Support
B5	Hex Head Screw, M10x40
B6	Base
B7	Table Support w/ Indicator
B8	Table Crank
B10	Gear Pin
B11	Set Screw, Socket, M6x10
B12	Bevel Table Lock Screw
B13	Table Clamp
B14	Arm w/ Scale
B15	Table
B16	Arm Locking Handle
B17	Helical Gear
B18	Worm
B19	Collar

Base and Table Assembly Drawing

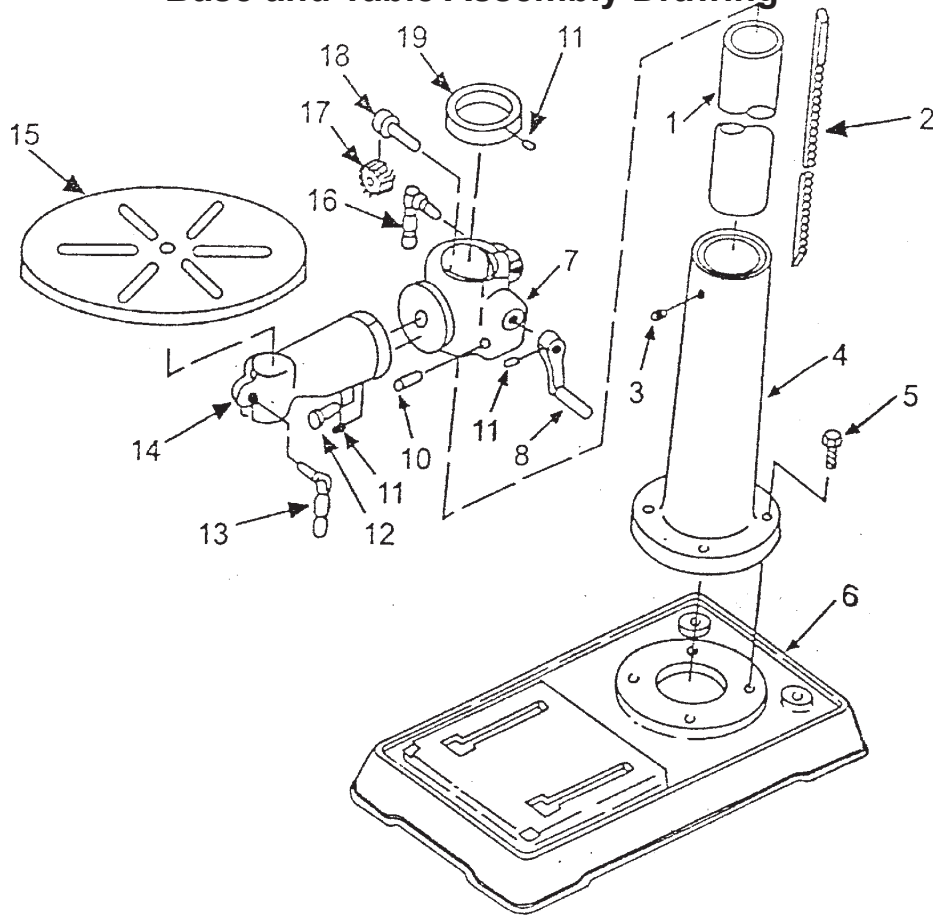

When ordering a part from this drawing,
add a "B" prefix to the part number.